

Digi Doser General 2

4309020 230V

4309040 12V

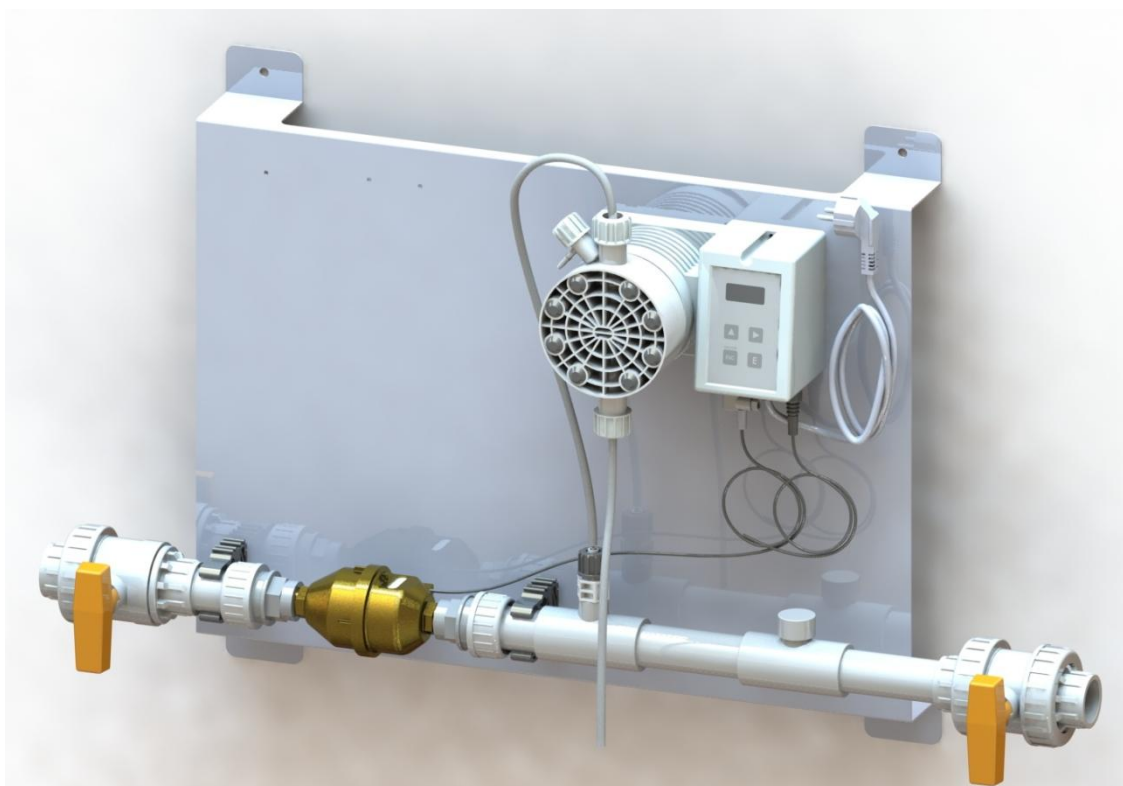

EN	Digi Doser General 2	
	Operating instructions.....	2



Digi Doser General

FOREWORD

Product description

Digi Doser General is a dosing system for additives in drinking water systems. The system is equipped with a digital diaphragm pump, which uses pulses from a water meter to deliver correct doses of additives into the water pipeline. The pump is suitable for dosing medication, vitamins and minerals, as well as additives based on organic acids.

TABLE OF CONTENTS

Foreword	2
Product description	2
Table of Contents	2
1. The device	3
1.1 Diagram of parts	3
1.2 Parts list	4
1.3 Articles included.....	5
2. Installation instructions	6
2.1 Preparation	6
2.2 Mounting the water supply and dosing pumps.....	7
2.3 Fitting the device.....	7
3. Setting the device into operation	9
3.1 Venting and starting the device.....	9
3.2 Technical data for the pump	10
4. Settings.....	10
4.1. Factory settings.....	10
4.2 Modifying dosage.....	14
5. Maintenance	14
5.1 Cleaning the pump.....	14
6. Trouble shooting.....	14

Guarantee

- The firm Schippers guarantees this product against manufacturing defects for a period of 12 months.
- The guarantee applies to both mechanical and electronic components as well as for working hours.
- Shipments to the user are covered by the guarantee.
- Movements are at the user's risk.
- The guarantee is valid for the first owner, at the original place of installation.

Excluded from the guarantee:

- Damage caused by improper installation, faults in the pipeline and high water pressure or pressure surges.
- Damage caused by frost, fire, accident, unreasonable use or negligence on the part of the user.
- Damage caused by the presence of iron, water hardness, algae, organic matter or other substances in the water for which the appliance is not suitable. In some cases, water treatment should be provided.

1. THE DEVICE

1.1 Diagram of parts

The image below is an exploded diagram of the device's parts.

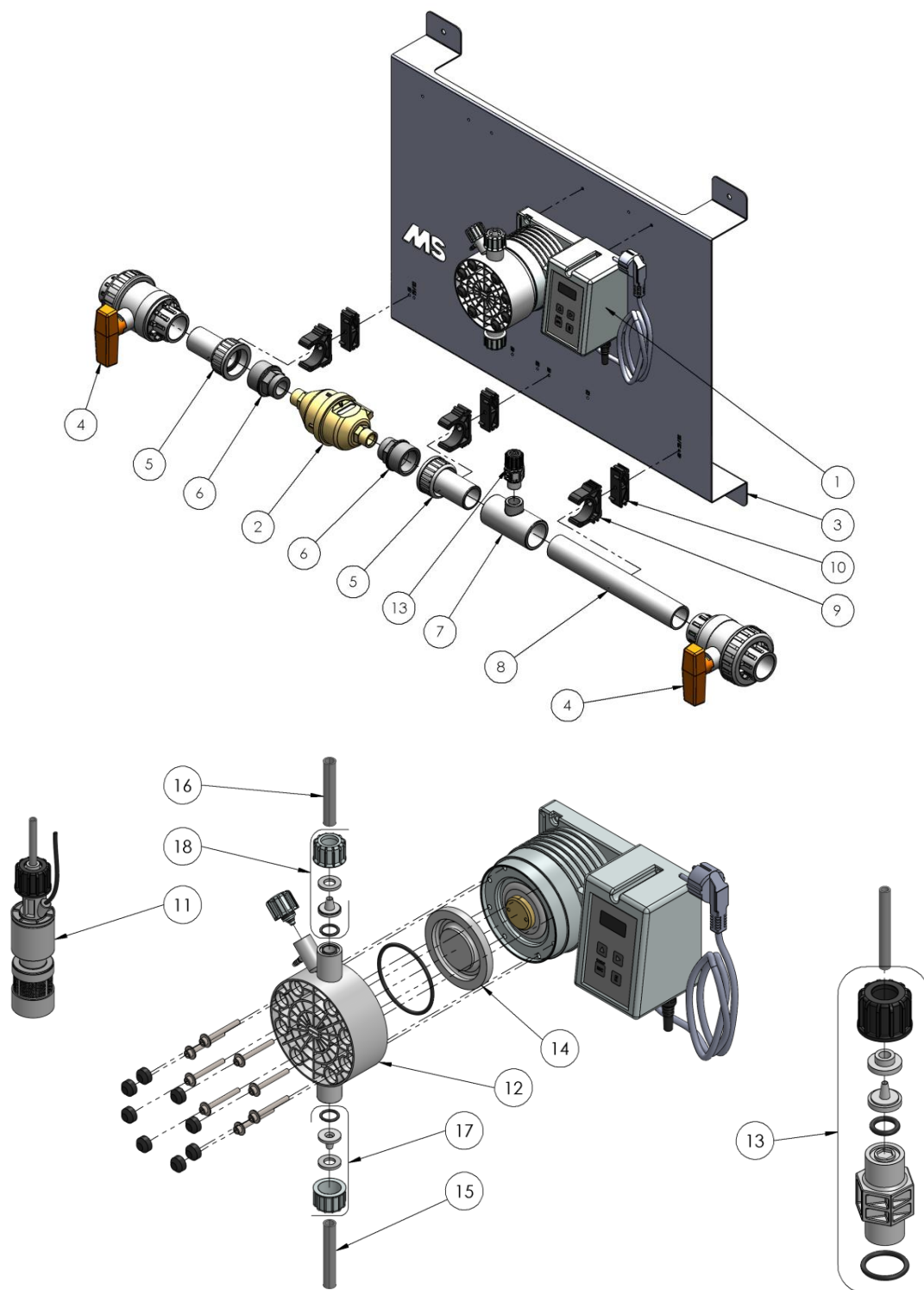

Fig. 1.1 Diagram of parts

1.2 Parts list

The parts list below relates to the diagram of parts in paragraph 1.1.

Digi Doser General 2 Spare Parts		
Code	Article number:	Description
1	8800414	General pump, 30 litres, 3 bar 230V
	8800417	Pump General, 30 litres, 1 bar 12V
2	8804085	Water meter ¾", 2.5 m3/h
3	8804083	Mounting plate, SS, 800 x 500 mm
4	8800250	Ball valve, PVC, 40 mm
5	8800221	-coupling 40 x 1½"
6	8800258	Bush, inline, 1½" x ¾"
7	8800244	T-piece 90° 40 x ½" x 40
8	8800384	PVC pipe, 40 mm, L = 270 mm
9	8800293	Pipe clip, 40 mm
10	8800253	Spacer, 40 mm
11	8804574	Dry run protection, Acid, 1/2" 8 x 12
12	8804585	Pump head S, Digi Doser, General
13	8804580	General, Injector, 1 bar, 1/2" 4 x 6
14	8804025	Diaphragm S
15	8800448	Suction hose 2 m 8 x 12 Digi Doser
16	8804596	Pressure hose 2 m 8 x 10 Digi Doser
17	8804595	Hose fitting kit 3/4" 4 x 6, General
18	8804592	Hose fitting kit 3/4" 8 x 10, General
-	8804599	Fuse 1 A

Fig. 1.2 Parts list

1.3 Articles included

- Digi Doser mounting plate
- Digi Doser water pipework
 - 3 x Pipe clamps
 - 3 x spacer blocks
 - Manometer, including T-piece
 - 4 x threaded bolts \varnothing 8 x 60 mm
 - 4 x plugs bolts \varnothing 8 x 10 mm
 - 1 x 50 cc Syringe
- General 2 Pump
 - Suction hose
 - Dry-run protection
 - Pressure hose
 - Injector
 - 2 x screws
 - Fuse
- Digi Doser User Manual

Optional:

- Pressure regulator with manometer
- Water filter set

2. INSTALLATION INSTRUCTIONS

2.1 Preparation

We advise you to fit a bypass (fig. 2.1.) around the pump's location. In this way, you can continue to use the main pipeline and easily maintain a water supply to your animals during maintenance or in case of any fault.

For proper dosing, the pump must be calibrated according to the water pressure. That is why there must always be a manometer installed in front of the Digi Doser.

A supply of clean water and the proper pressure are prerequisites for proper dosing system function. If that either of those is not optimal, you can install an additional water filter and/or pressure regulator (see Fig. 2.1):

1. Water filter set (4309554)
2. Pressure reduction set (8804050) / Manometer

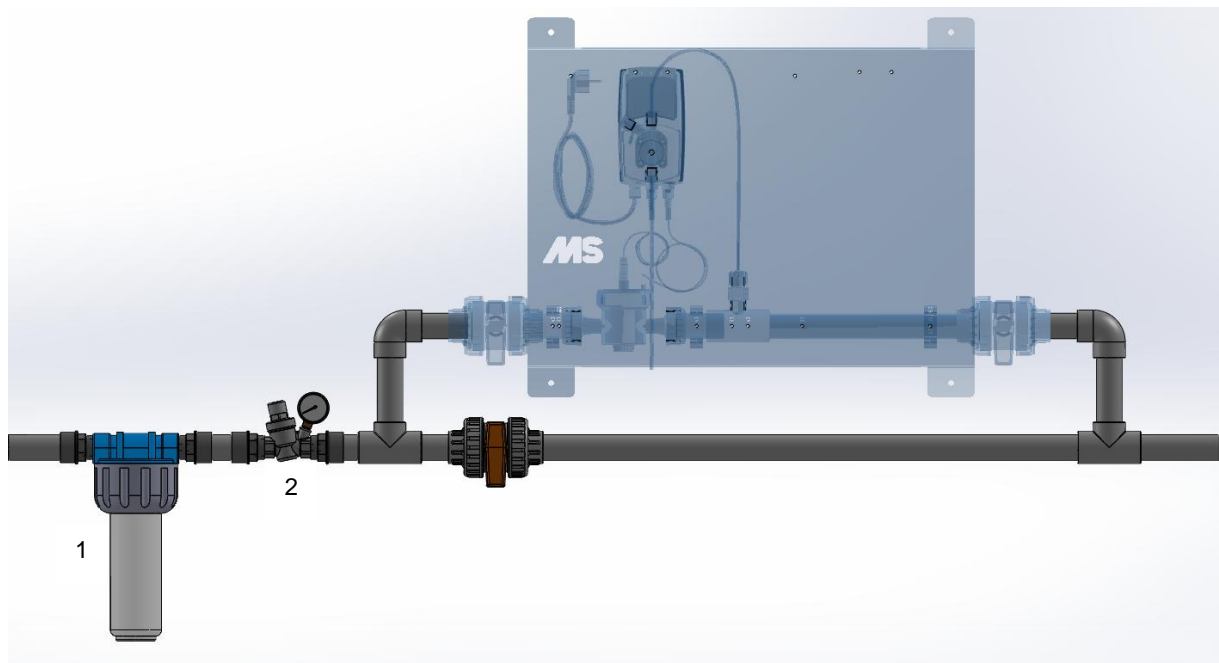

Fig. 2.1. Diagram of the bypass

2.2 Mounting the water supply and dosing pumps

Click the 3 pipe clamps onto the spacer blocks and mount them, using the provided screws into holes number 7, 11 and 13.

The pump must be mounted using holes 4 and 6.

Then click the water pipe into the pipe clamps.

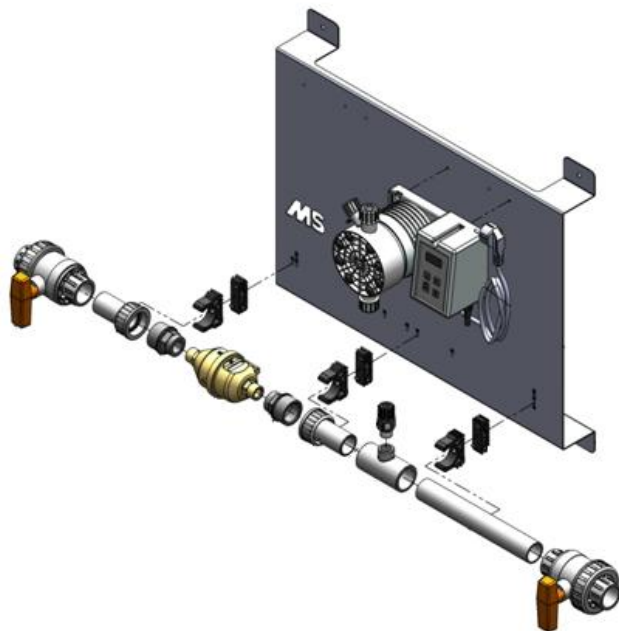
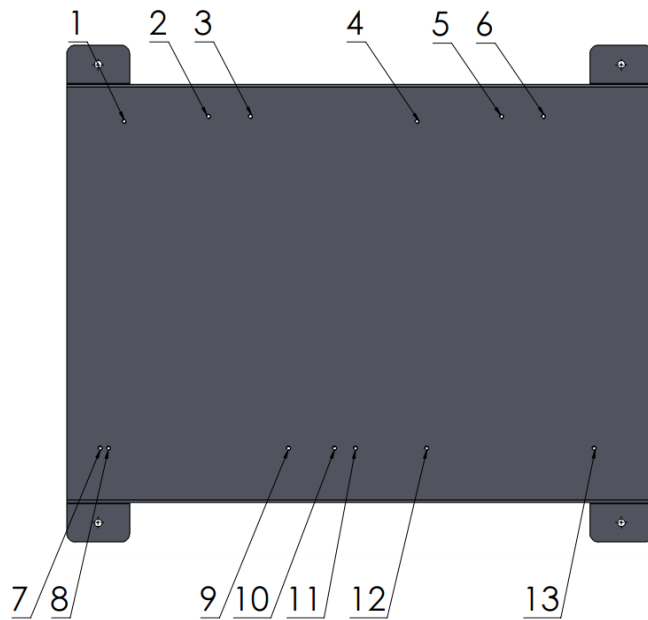

2.3 Fitting the device

Turn off the water supply and cut away the supply pipeline. Fit the necessary fittings for connecting the pump.

- Mark the four mounting holes (level) on the wall behind.
- Drill four holes (\varnothing 10 mm) in the wall where you are mounting the device.
- Mount the device on the wall, using the supplied plugs and bolts.
- Connect the water supply to the inlet and the outlet pipe (for treated water) to the outlet. Open the ball valves at the pump inlet and outlet (Figure 1).
- Connect the dry-run protection cable to the "level" connector on the dosing pump (Figure 2).
- Connect the suction hose with the dry-run protection to the underside of the pump (Figure 3).
- In the same way, connect the pressure hose to the topside of the pump and to the injector (Figure 4).

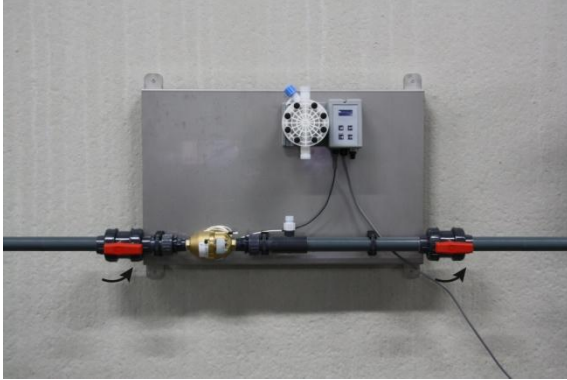

Figure 1: Open the ball valves



Figure 2: Connecting the dry-run protection and watermeter

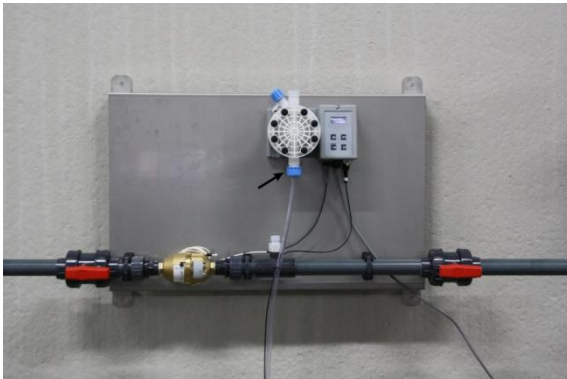

Figure 3: Connecting the suction hose

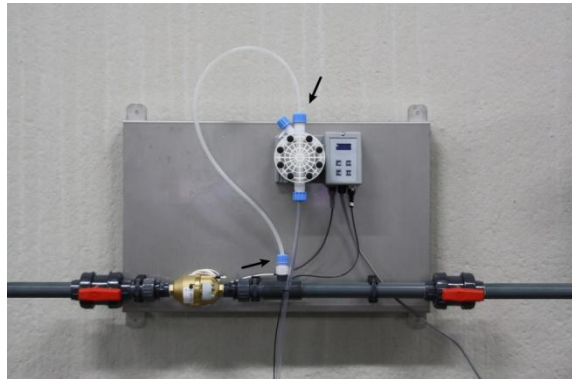

Figure 4: Connecting the pressure hose

3. SETTING THE DEVICE INTO OPERATION

3.1 Venting and starting the device

- Switch the pump on (Figure 5) and set the correct dosage (see paragraph 4.2)
- Place the product container under the device.
- Suspend the suction hose with the dry-run protection in the liquid (Figure 6).
- Connect the supplied syringe with the appropriate hose to the vent valve. Open the venting valve on the pump head and use the supplied syringe and tube to suck the air from the system until fluid runs into the syringe (Figure 7).
- Close the venting valve again.
- Press and hold down the right arrow button for 5 seconds. The system will then dispense for 30 seconds, so that the whole system fills with the product (Figure 8).
- The system is ready for use.



Figure 5: Switching the pump on



Figure 6: Put the suction hose in the liquid

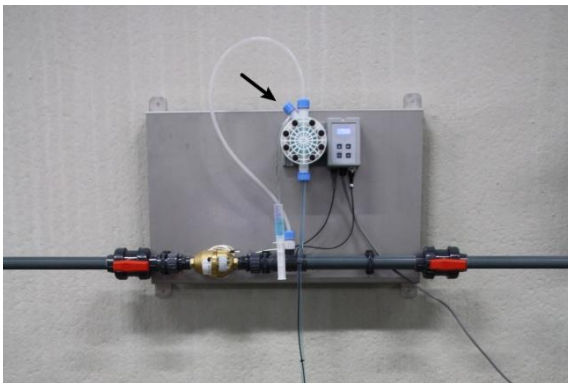

Figure 7: Venting the pump



Figure 8: Filling the pressure hose

3.2 Technical data for the pump

Max pressure	: 2 bar
Minimum Flow rate	: 15 litres per hour
Nominal flow rate	: 2,500 litres per hour
Maximum flow rate	: 3,000 litres per hour
Maximum injections per minute	: 120
Injections per impulse	: 4.20 cc at 2 bar
Pump output	: 30 litres per hour at 2 bar
Working temperature	: from 0 to 45 °C.
Voltage	: 12 VAC
Power use	: 27 W
Dimension (mm)	: 942 mm x (H) 500 mm x (D) 237 mm
Weight	: ± 14 kg
Protection rating	: IP 65
In/output connections	: 40 mm PVC

4. SETTINGS

4.1. Factory settings

The following settings are pre-set in your dosage pump:

CC per impulse (CC/ST)	: 4.20 cc
TEST	: 50 impulses
Reserve in supply tank (LEVEL)	: 02.000 litres
Water meter pulses (WMETER)	: 002 per litre
Unit (UNIT)	: litre
Password (PASSWORD)	: 0000
MODE (5)	: PERC
CONC%	: 100
Dosage	: 00.20%

Diagram 2

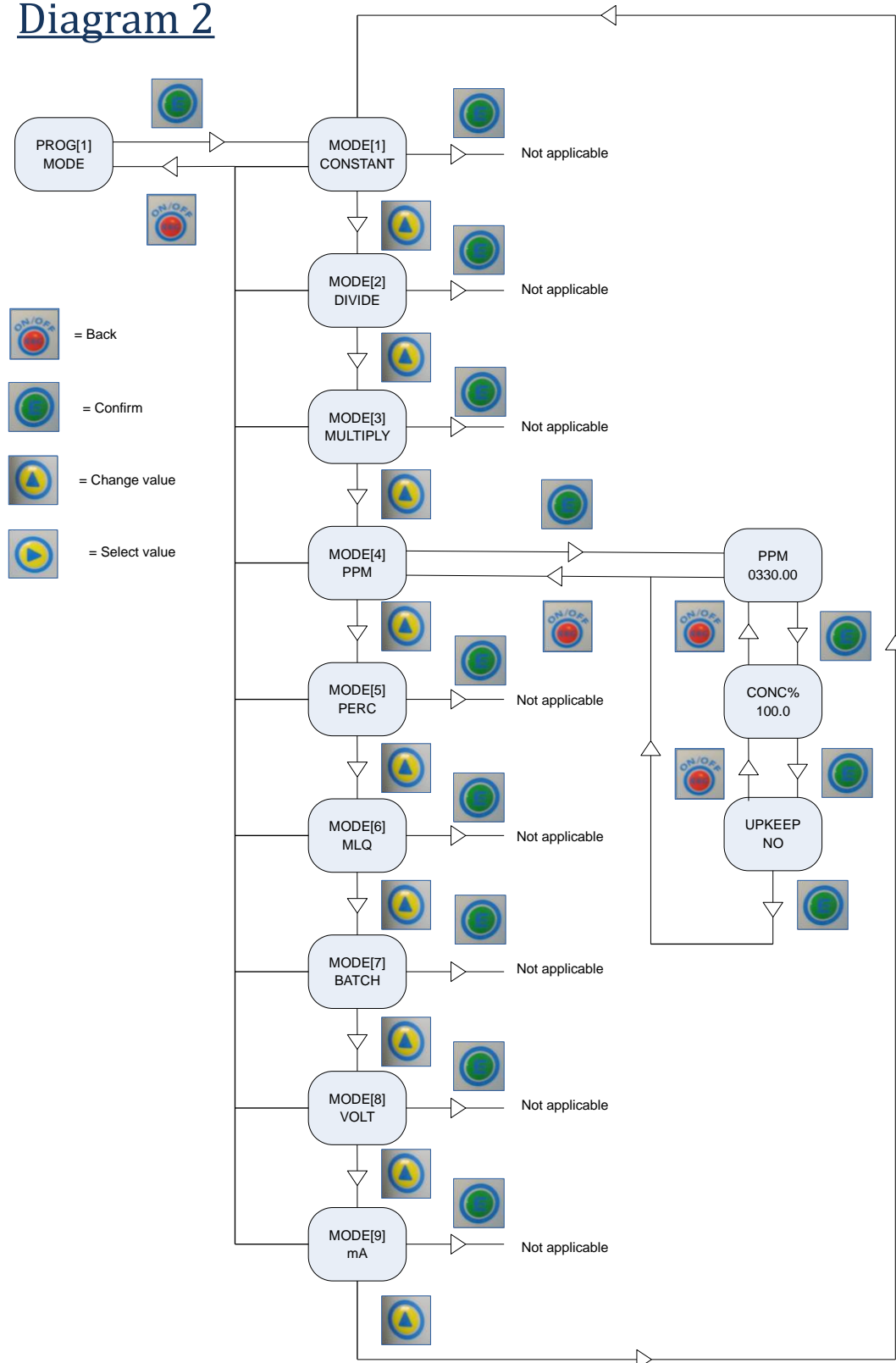
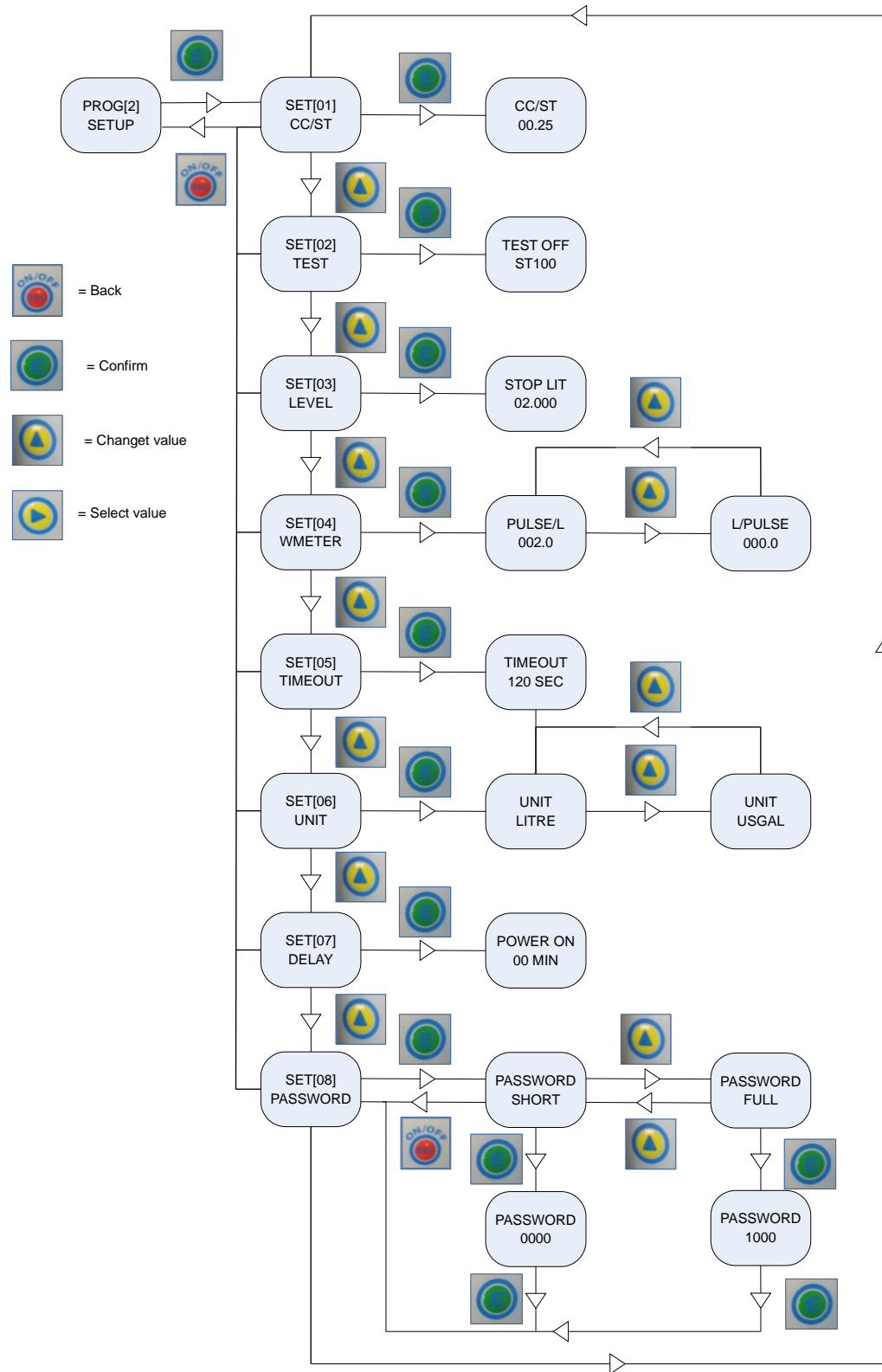

Diagram 3



4.2 Modifying dosage

Follow the steps below to modify dosage:

Diagram 4

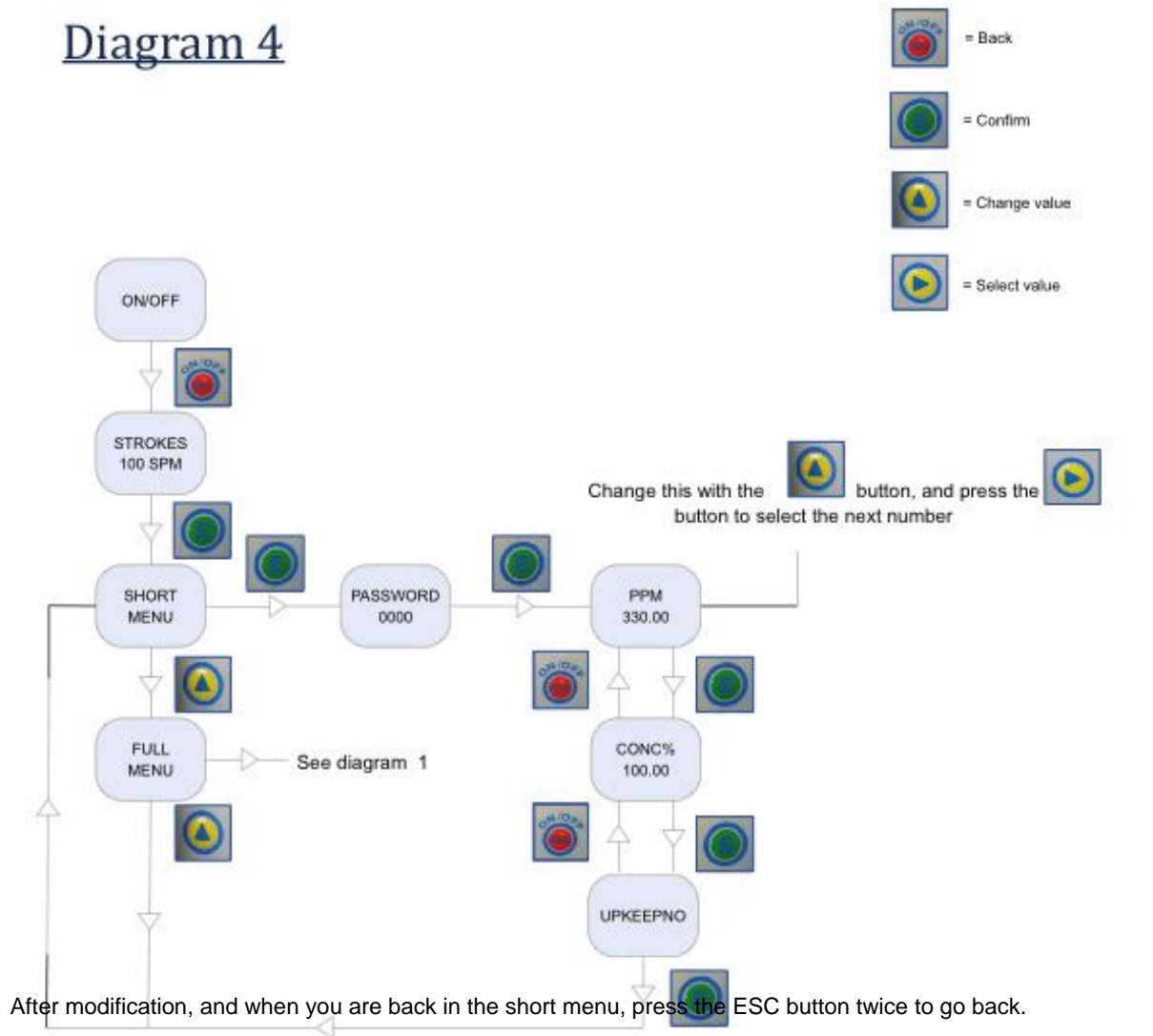

5. MAINTENANCE

5.1 Cleaning the pump

When the pump has been idle for an extended period, we advise flushing the device with a few litres of clean water.

6. TROUBLE SHOOTING

PROBLEM	CAUSE	SOLUTION
Fault handling	General	Press until "alarm" shows in the display. Then press to see notification of the fault in question.

Dosage is not accurate	Wrong setting	Check the percentage or PPM, concentration and number of water meter pulses
	Excessive pressure	Set the pressure to Max. 1.5 bar while water is removed by the pressure reducing valve
	Foot filter blocked or defective	Clean or replace the foot filter
	Pump head valves, foot filter or injector blocked or damaged.	Replace or clean the defective or dirty parts
	Electromagnet not delivering sufficient power (dull sound)	Send the pump to the repair service
Dosage too high	Injector Wrong injector mounted Defective injector	Check the injector There must not a number 5 on it
Product/water drains back into the supply tank	Defective/dirty injector or valve	Replace/clean the injector and/or the valves
	Checking the injector	Screw the pressure hose off, and if water leaks from the injector, replace it Or Screw the pressure hose off. Let the pump dose. Seal the pressure hose with your thumb. If the injector is remains blocked with enough pressure, → replace it.
The water meter is running and no product is dosed	Carry out the following test: Disconnect the water meter cable from the pump and connect the dry-run protection cable to it. Take the foot valve out of the supply tank and move the float up and down.	The pump should now inject with the movements of the float. If it does not, you should send the pump in for repair. If it does work, you need to replace the water meter's sensor, cable or the whole meter.
Strange symbols show on the display or certain pump functions are no longer accessible through the buttons	Fault on the printed circuit	Reset. Switch off the pump with the "ESC" button. Take the plug out of the power outlet. Press both arrow buttons and hold them down while reconnecting the power plug. The screen shows "load default" Reprogram the pump. If this does not succeed, you should send the pump in for repair.
Display/pump does not work	Power supply interrupted	Check the power supply
	Faulty fuse	Screw off the cover on the back of the pump and check/replace the fuse. If the problem recurs, send the pump in for repair
	Defective printed circuit	Send the pump to the repair service
Alarm "low level in the tank" # flashing (→alarm 1 level)	To pump the tank completely empty, a certain number of reserve litres are programmed. The pump keeps on working until this reserve is gone.	Possibly modify the reserve setting for the supply tank.
Pump doses continuously	Press  and read the mode from the display	Check the settings % PPM Continuous Impulse/litre (not litre/impulse)