

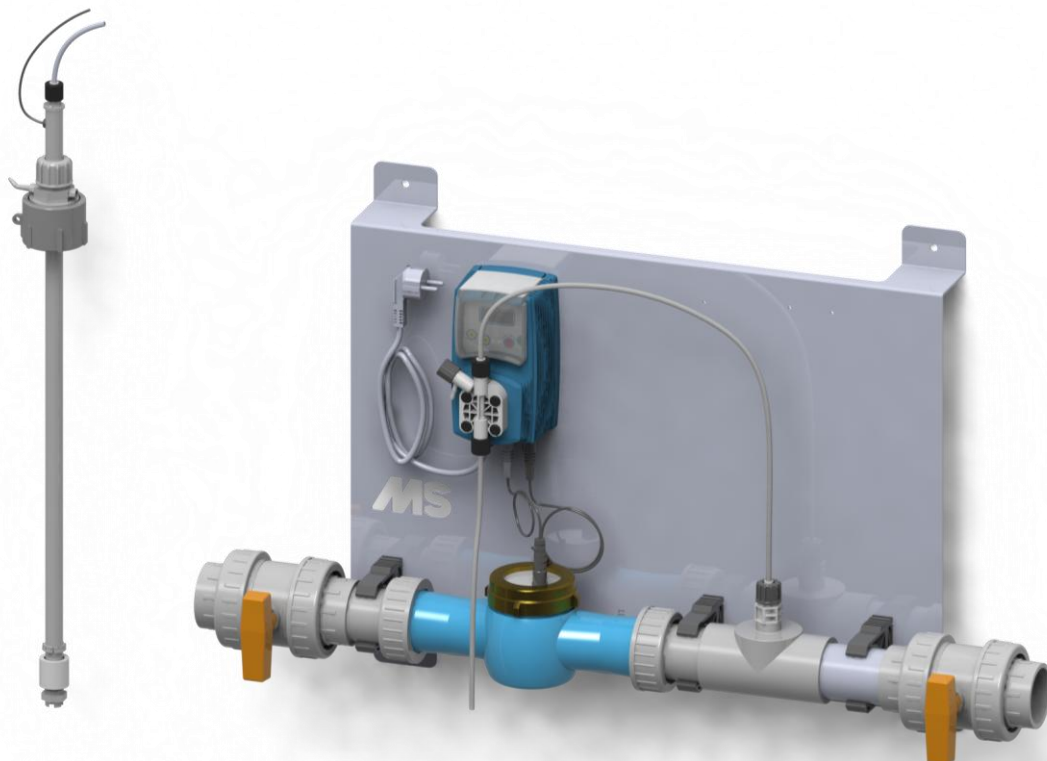

Digi Doser Di-O 20

4309533



EN Digi Doser Di-O 20
Operating instructions2



Digi Doser Di-O 20

FOREWORD

Product description

Digi Doser Di-O 20 is a dosing system for adding Di-O-Clean to the drinking water system. The system is equipped with a digital diaphragm pump, which uses pulses from a water meter to deliver correct doses of Di-O-Clean into the water pipeline. The dosing system is especially designed to provide low dosages in an accurate manner.

TABLE OF CONTENTS

Foreword	2
Table of Contents	2
1. The device	3
1.1 Diagram of parts.....	3
1.2 Parts list	4
1.3 Articles included	4
2. Installation instructions	5
2.1 Preparation	5
2.2 Mounting the water supply and dosing pumps	7
2.3 Fitting the device.....	7
3. Setting the device into operation	9
3.1 Venting and starting the device.....	9
3.2 Technical data for the pump	10
4. Settings	10
4.1 Factory settings.....	10
4.2 Modifying dosage	14
5. Maintenance.....	15
5.1 Cleaning the pump.....	15
6. Trouble shooting	15

Guarantee

- The firm Schippers guarantees this product against manufacturing defects for a period of 12 months.
- The guarantee applies to both mechanical and electronic components as well as for working hours.
- Shipments to the user are covered by the guarantee.
- Movements are at the user's risk.
- The guarantee is only valid for the first owner, at the original place of installation.

Excluded from the guarantee:

- Damage caused by improper installation, faults in the pipeline and high water pressure or pressure surges.
- Damage caused by frost, fire, accident, unreasonable use or negligence on the part of the user.
- Damage caused by the presence of iron, water hardness, algae, organic matter or other substances in the water for which the appliance is not suitable. In some cases, water treatment should be provided.

1. THE DEVICE

1.1 Diagram of parts

The image below is an exploded diagram of the device's parts.

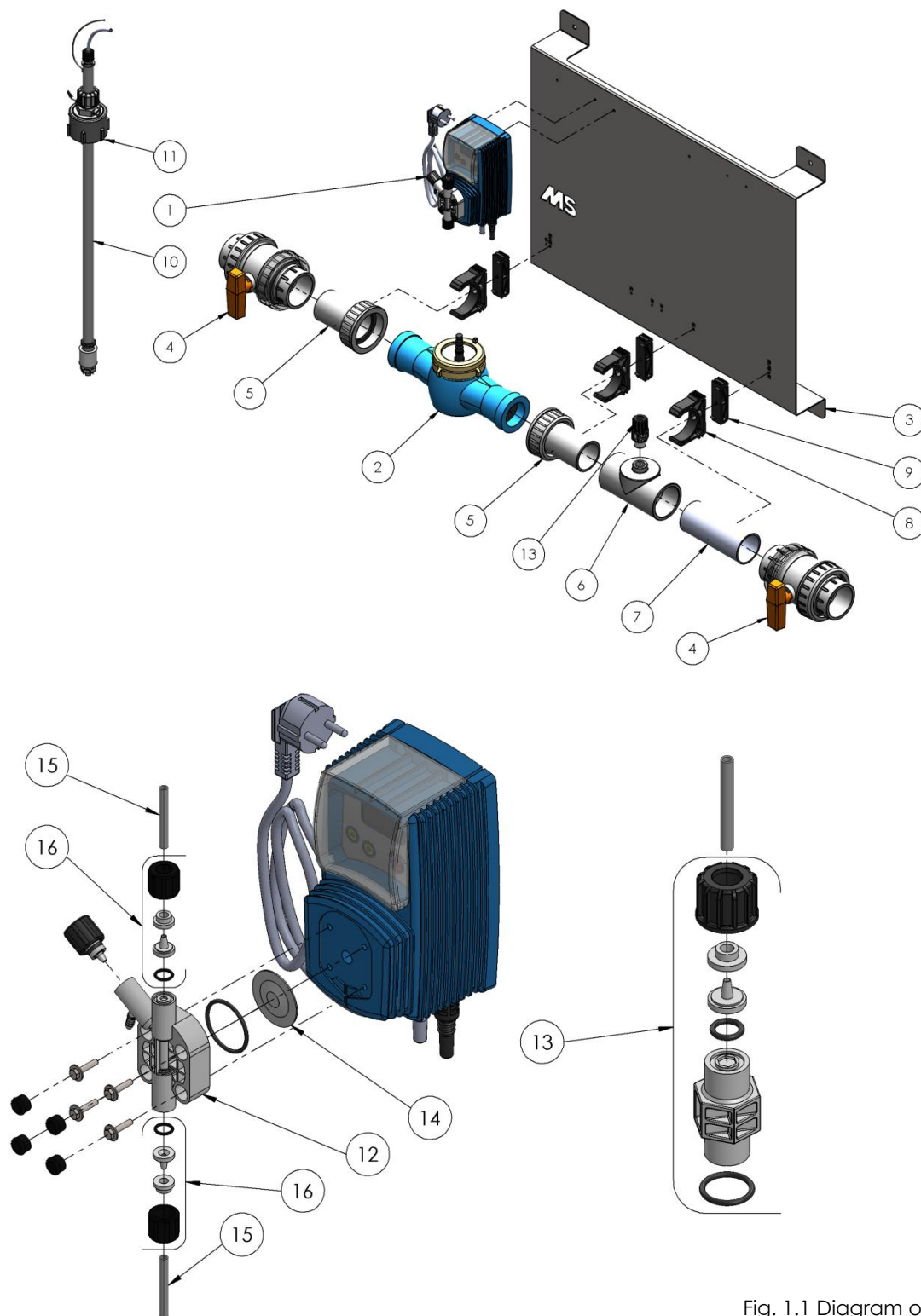

Fig. 1.1 Diagram of parts

1.2 Parts list

The parts list below relates to the diagram of parts in paragraph 1.1.

Digi Doser Di-O 20 Spare Parts		
Code	Article number:	Description
1	8800411	Di-O-Clean pump, 10 litres, 5 bar
2	8800454	Water meter 2", 20 m ³ /h
3	8800287	Mounting plate
4	8800252	Ball valve, PVC, 63 mm
5	8800223	⅔-coupling 63 x 1½"
6	8800246	T-piece 90° 63 x ½" x 63
7	8800386	PVC pipe, 63 mm, L = 150 mm
8	8800295	Hose clip, 63 mm
9	8800255	Spacer, 63 mm
10	8800286	Dry run protection, LASP, 72 cm
11	8804534	Di-O-Clean can adapter
12	8804514	Digi Doser Di-O Pump head, K
13	8804528	Di-O-Clean Injector, 5 bar, 1/2" 4 x 6
14	8804511	Diaphragm, K
15	8804535	Pressure and suction hose for Digi Doser Di-O, 2 m
16	8804588	Hose fitting kit 3/8" 4 x 6 Di-O
17	8804599	Fuse 1 A

Fig. 1.2 Parts list

1.3 Articles included

- Digi Doser mounting plate
- Digi Doser water pipework
 - 3 x Pipe clamps
 - 3 x spacer blocks
 - Manometer, including T-piece
 - 4 x threaded bolts Ø 8 x 60 mm
 - 4 x plugs bolts Ø 8 x 10 mm
 - 1 x 50 cc Syringe
- Di-O-Clean pump (blue)
 - Suction hose
 - Pressure hose
 - Injector
 - 2 x screws
 - Fuse
- Dry-run protection LASP 72 cm
- Signal splitter, with cable
- Digi Doser User Manual
- Digi Doser instruction card

Optional:

- Pressure regulator with manometer
- Water filter set

2. INSTALLATION INSTRUCTIONS

2.1 Preparation

We advise you to fit a bypass (fig. 2.1.) around the pump's location. In this way, you can continue to use the main pipeline and easily maintain a water supply to your animals during maintenance or in case of any fault.

For proper dosing, the pump must be calibrated according to the water pressure. That is why there must always be a manometer installed in front of the Digi Doser.

A supply of clean water and the proper pressure are prerequisites for proper dosing system function. If the water supply is not optimal, you can install an additional water filter and/or pressure regulator (see Fig. 2.1):

1. Water filter (4309555)
2. Pressure regulator (8804001) / Manometer

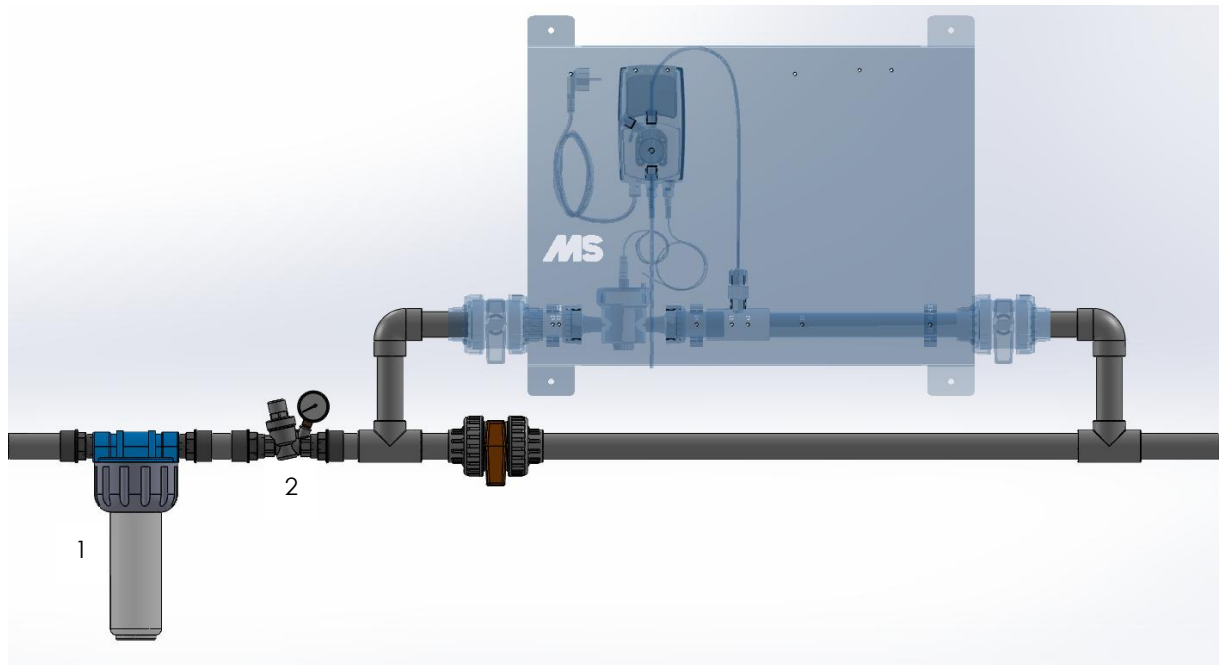
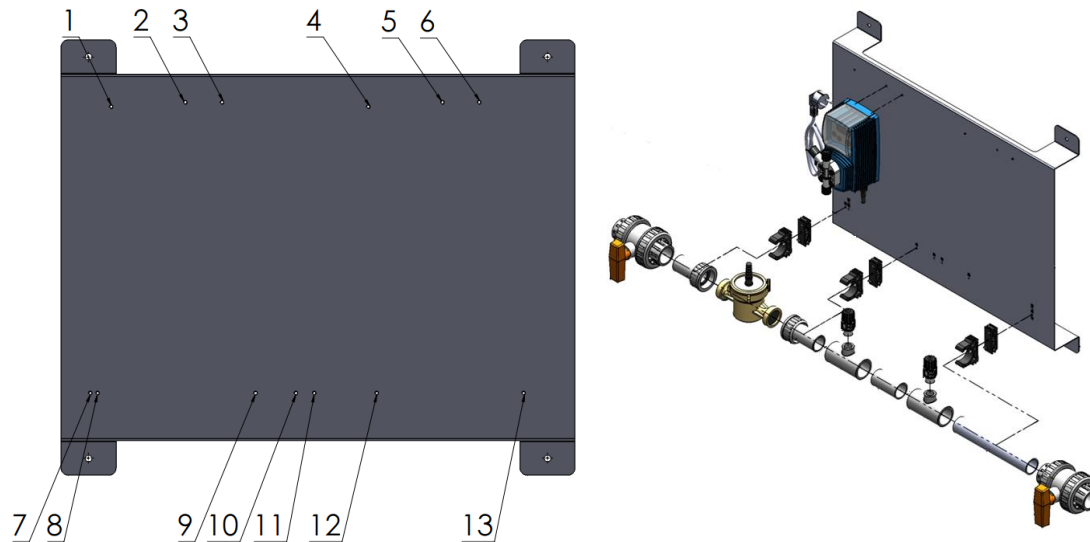

Fig. 2.1 Diagram of the bypass

2.2 Mounting the water supply and dosing pumps

Click the 3 pipe clamps onto the spacer blocks and mount them, using the provided screws into holes number 7, 11 and 13.

The DI-O-Clean pump (blue) must be mounted using holes 2 and 3. Then click the water pipe into the pipe clamps.



Bring on 11 layers of teflon tape on the injector and screw it into the T-part.

2.3 Fitting the device

Turn off the water supply and cut away the supply pipeline. Fit the necessary fittings for connecting the pump.

- Mark the four mounting holes (level) on the wall behind.
- Drill four holes (Ø 10 mm) in the wall where you are mounting the device.
- Mount the device on the wall, using the supplied plugs and bolts.
- Connect the water supply to the inlet and the outlet pipe (for treated water) to the outlet. Open the ball valves at the pump inlet and outlet (Figure 1).
- Connect the dry-run protection cable to the "level" connector on the dosing pump (Figure 2).
- Screw the signal splitter into the "input" on the bottom of the pump. Connect the cable from the water meter to the signal splitter. (Figure 2)
- Connect the suction hose with the dry-run protection to the underside of the pump (Figure 3).
- In the same way, connect the pressure hose to the topside of the pump and to the injector (Figure 4).

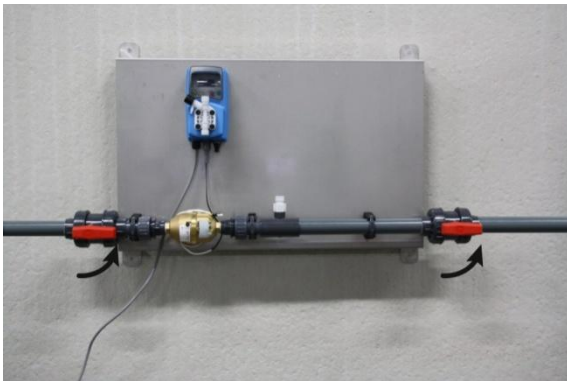

Figure 1: Open the ball valves



Figure 2: Connect the dry-run protection and water



Figure 3: Connecting the suction hose

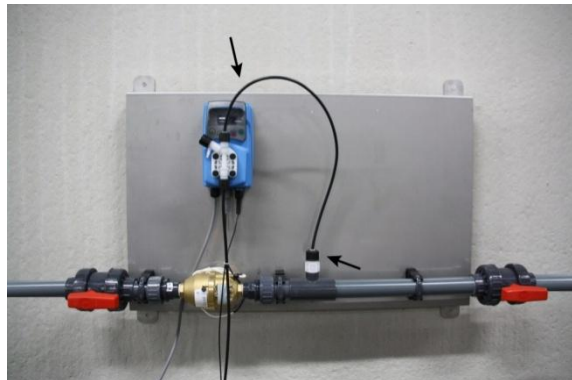

Figure 4: Connecting the pressure hose

3. SETTING THE DEVICE INTO OPERATION

3.1 Venting and starting the device

- Switch the pump on (Figure 5) and set the correct dosage (see paragraph 4.2).
- Place the container of Di-O-Clean under the device.
- Connect the suction lance to the container, using the supplied adapter (Figure 6).
- Connect the supplied syringe with the appropriate hose to the vent valve. Open the venting valve on the pump head and use the supplied syringe and tube to suck the air from the system until fluid runs into the syringe (Figure 7).
- Close the venting valve again.
- Press and hold down the right arrow button for 5 seconds. The system will then dispense for 30 seconds, so that the whole system fills with Di-O-Clean (Figure 8).
- The system is ready for use.



Figure 5: Switching the pump on



Figure 6: Connecting the suction lance to the

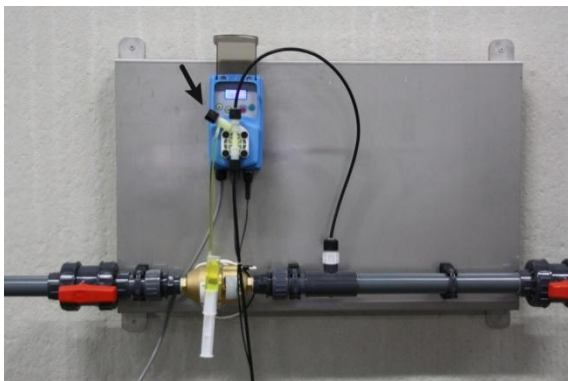

Figure 7: Venting the pump



Figure 8: Filling the pressure hose

3.2 Technical data for the pump

Max pressure	: 5 bar
Minimum Flow rate	: 450 litres per hour
Nominal flow rate	: 15,000 litres per hour
Maximum flow rate	: 30,000 litres per hour
Maximum injections per minute	: 180
Injection per impulse	: 0.93 cc at 5 bar
Pump output	: 10 litres per hour at 5 bar
Working temperature	: from 0 to 45 °C.
Voltage	: 230 VAC
Power use	: 16 W
Dimension (mm)	: 987 mm x (H) 500 mm x (D) 253 mm
Weight	: ± 17 kg
Protection rating	: IP 65
In/output connections	: 63 mm PVC

4. SETTINGS

4.1 Factory settings

The following settings are pre-set in your dosage pump:

CC per impulse (CC/ST)	: 0.93 cc
TEST	: 100 impulses
Reserve in supply tank (LEVEL)	: 02.000 litres
Water meter pulses (WMETER)	: 004 per litre
Unit (UNIT)	: litre
Password (PASSWORD)	: 0000
MODE (4)	: PPM
Dosage	: PPM
CONC %	: 100
Upkeep	: NO

Diagram 1

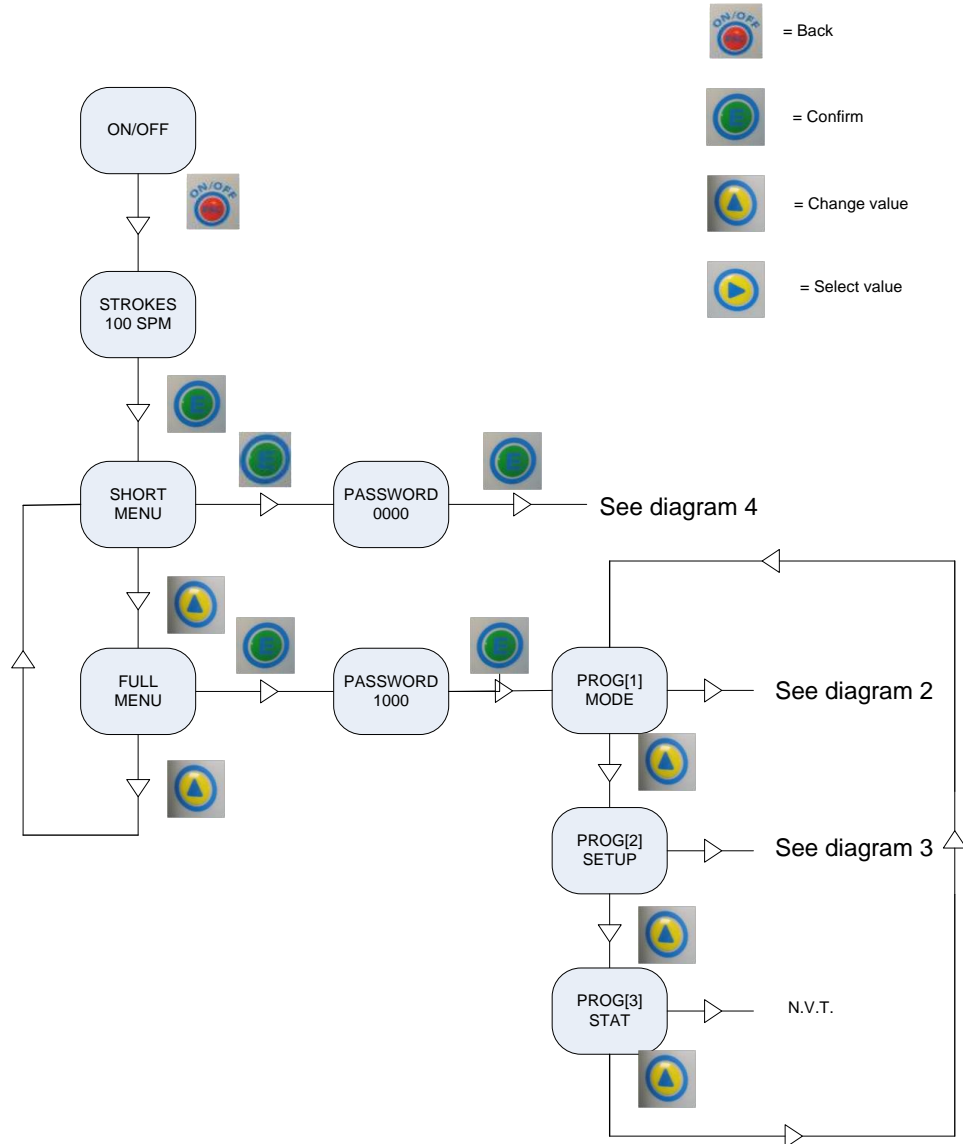

Diagram 2

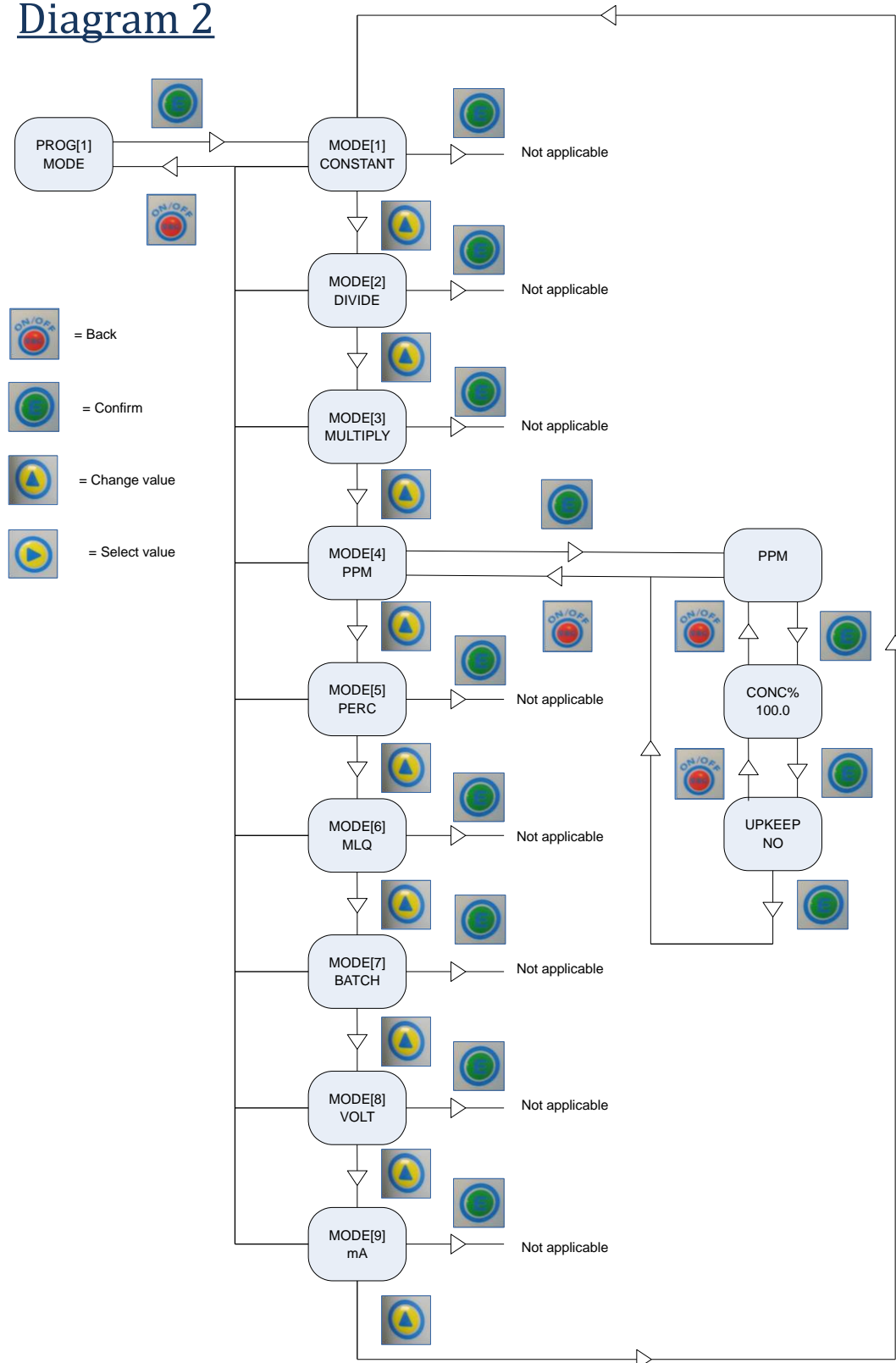
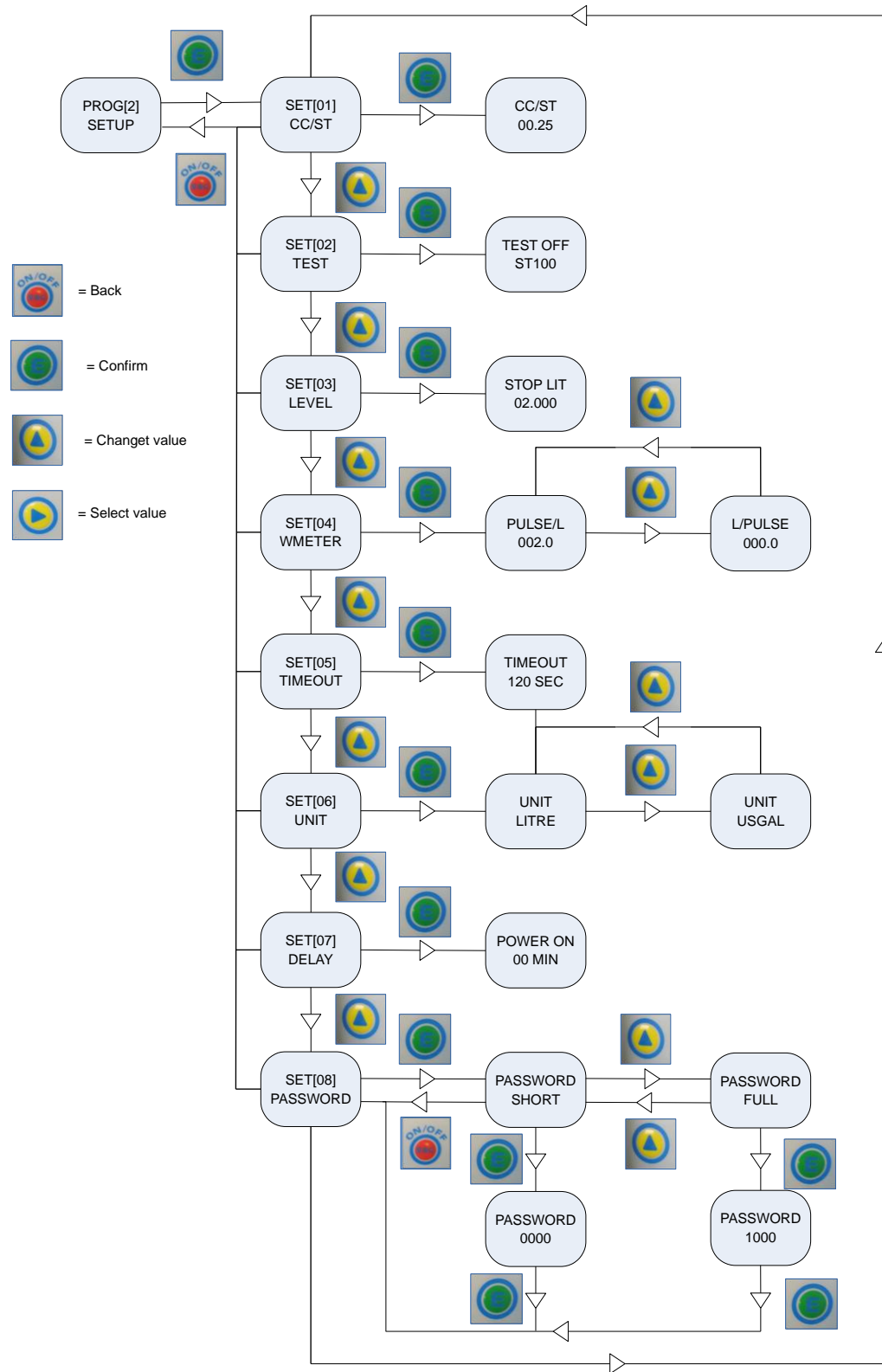

Diagram 3



4.2 Modifying dosage

Follow the steps below to modify dosage:

Diagram 4

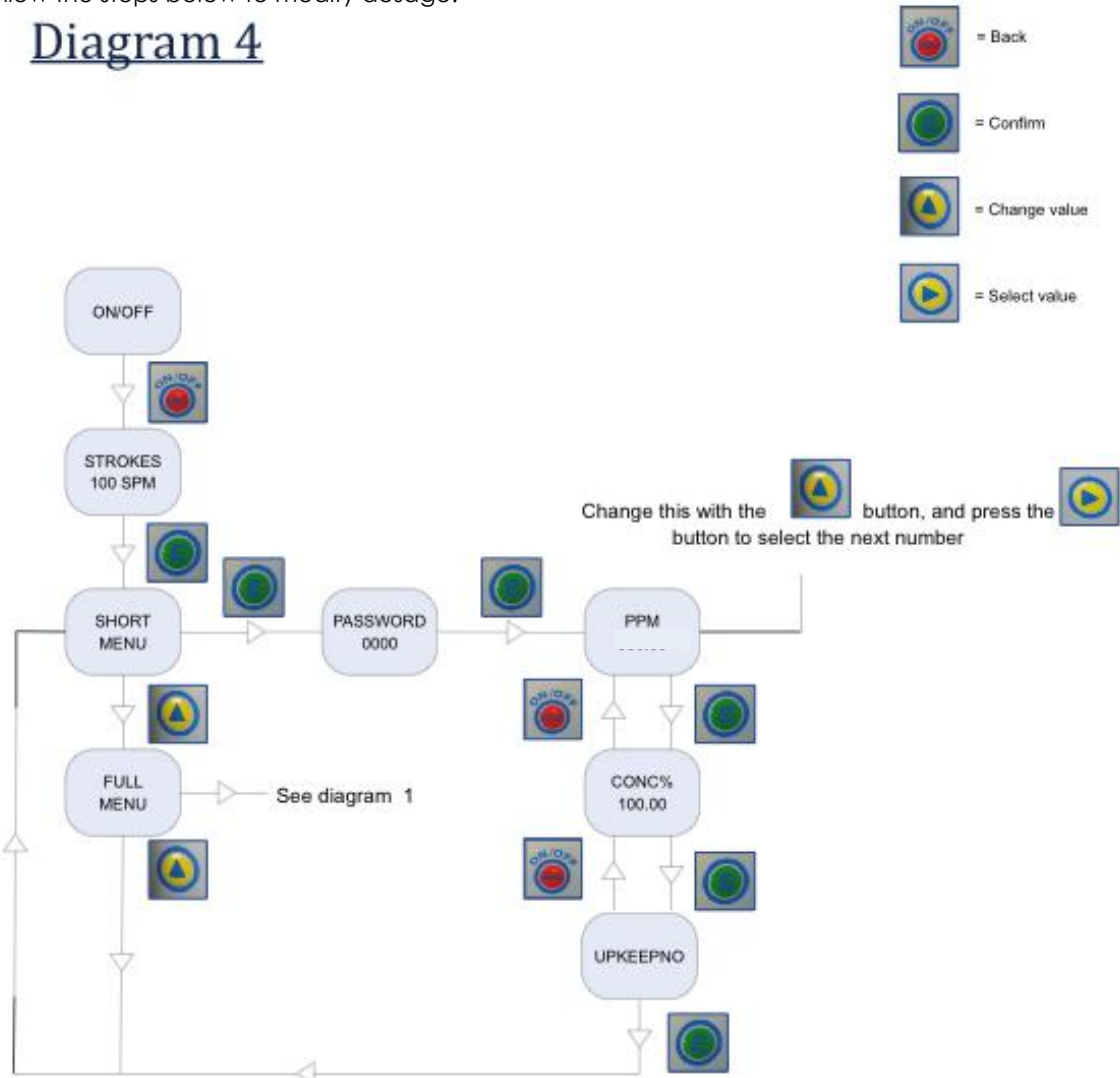

-  = Back
-  = Confirm
-  = Change value
-  = Select value

After modification, and when you are back in the short menu, press the ESC button twice to go back.

5. MAINTENANCE

5.1 Cleaning the pump

When the pump has been idle for an extended period, we advise flushing the device by sucking up a few litres of clean water.

6. TROUBLE SHOOTING

PROBLEM	CAUSE	SOLUTION
Fault handling	General	Press ⏸ until "alarm" shows in the display. Then press ⏪ to see notification of the fault in question.
Dosage is not accurate	Wrong setting	Check the percentage or PPM, concentration and number of water meter pulses
	Excessive pressure	Set the pressure to Max. 5 bar while water is released by the pressure reducing valve
	Foot filter blocked or defective	Clean or replace the foot filter
	Pump head valves, foot filter or injector blocked or damaged.	Replace or clean the defective or dirty parts
	Electromagnet not delivering sufficient power (dull sound)	Send the pump to the repair service
Dosage too high	Injector Wrong injector mounted Defective injector	Check the injector (number 5 on the injector)
Product/water drains back into the supply tank	Defective/dirty injector or valve	Replace/clean the injector and/or the valves
	Checking the injector	Screw the pressure hose off, and if water leaks from the injector, replace it Or Screw the pressure hose off. Let the pump dose. Seal the pressure hose with your thumb. If the injector remains blocked with enough pressure, → replace it.
The water meter is running and no product is dosed	Carry out the following test: Disconnect the water meter cable from the pump and connect the dry-run protection cable to it. Take the foot valve out of the supply tank and move the float up and down.	The pump should now inject with the movements of the float. If it does not, you should send the pump in for repair. If it does work, you need to replace the water meter's sensor, cable or the whole meter.

PROBLEM	CAUSE	SOLUTION
Strange symbols show on the display or certain pump functions are no longer accessible through the buttons	Fault on the printed circuit	Reset. Switch off the pump with the "ESC" button. Take the plug out of the power outlet. Press both arrow buttons and hold them down while reconnecting the power plug. The screen shows "load default" Reprogram the pump. If this does not succeed, you should send the pump in for repair.
Display/pump does not work	Power supply interrupted	Check the power supply
	Faulty fuse	Screw off the cover on the back of the pump and check/replace the fuse. If the problem recurs, send the pump in for repair
	Defective printed circuit	Send the pump to the repair service
Alarm "low level in the tank" # flashing (→alarm 1 level)	To pump the tank completely empty, a certain number of reserve litres are programmed. The pump keeps on working until this reserve is gone.	Possibly modify the reserve setting for the supply tank.
Pump doses continuously	Press  and read the mode from the display	Check the settings % PPM Continuous Impulse/litre (not litre/impulse)